

Hybrid Manufacturing

From Laser Cladding
to Additive Manufacturing



Powder-Based Laser Cladding

Laser cladding with powdered feedstocks is the most advanced approach existing today for repairing or optimizing workpieces of all kinds. This applies especially to processing of large surfaces and deposition of multiple layers (additive manufacturing).

A laser beam melts the substrate together with an injected powder to create a melt pool that is deposited onto the workpiece.

The result is an improved surface free of pores and cracks. If the properties of the added material are carefully chosen, it very effectively protects the workpiece from corrosion and wear.

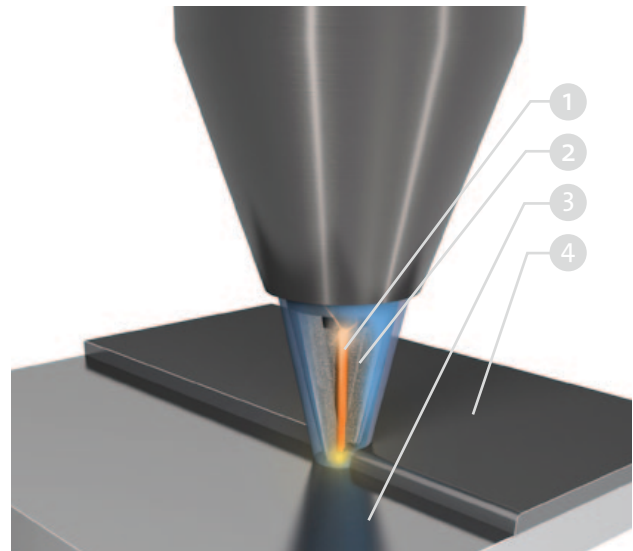

1. Laser beam 2. Powder feed 3. Workpiece
4. Added layer

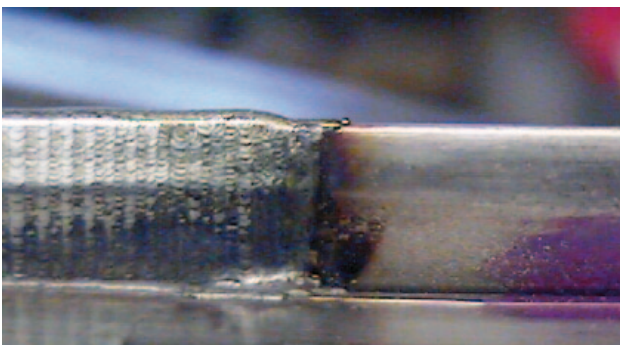
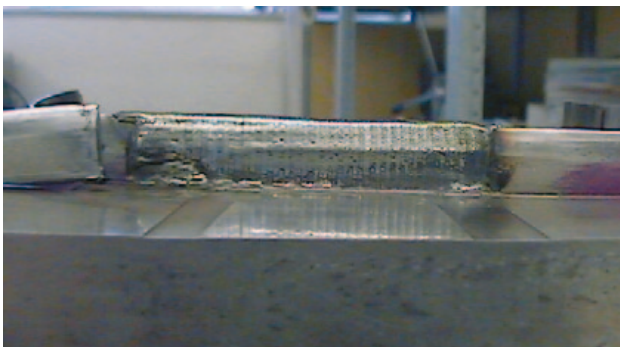

Powder-based laser cladding: repair of a mold for an automotive parts supplier.

The Powder Nozzle from OR Laser

The research & development department of OR Laser collaborated with the Fraunhofer Institute to develop an efficient, easy-to-install powder nozzle for the DIODELINE product line. It is the first such system that allows both wire- and powder-fed cladding, resulting in 10 times the usual efficiency.

The coaxial configuration of the powder nozzle and laser lets material be deposited regardless of the substrate's direction of movement and ensures an extremely reliable process. It is therefore also suitable for 3D printing (additive manufacturing).

Coaxial feeding of metal powder also enables very flexible addition of volume to the workpiece: it can grow in any direction.

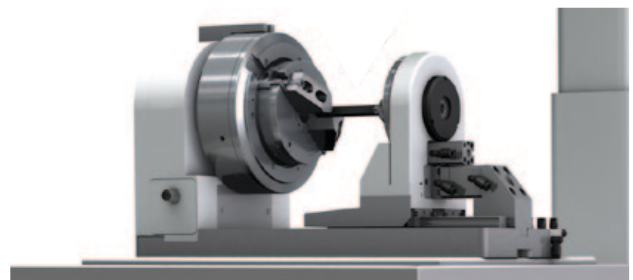

A rotary axis for machining circularly symmetrical workpieces.

Rapid Clamping System for Time Savings

The powder nozzle from OR Laser features an innovative quick-change system that is straightforward to install in any system of the DIODELINE family. It's also extremely compact. Because the quick-change system is optimized for all of the required inputs, there's no need to readjust the nozzle after changing tools.

The quick-change system also lets the user manually perform minor or simple jobs with wire feed. If

required, the powder nozzle can then be reattached for automatic coating of larger surfaces.

An integrated anti-collision feature eliminates the risk of damaging the lens in complex or critical beam delivery situations.

Compatible with DIODELINE

For pulsed or continuous beams, powder-based laser cladding can be seamlessly integrated into the flexible concept of the DIODELINE product family from OR Laser.

For industrial applications, the process is mainly used in fully automatic mode with CAD/CAM system support. Now you can also combine it with the ORLAS SUITE, OR Laser's new CAM software solution, for automatic coating of complex workpieces.

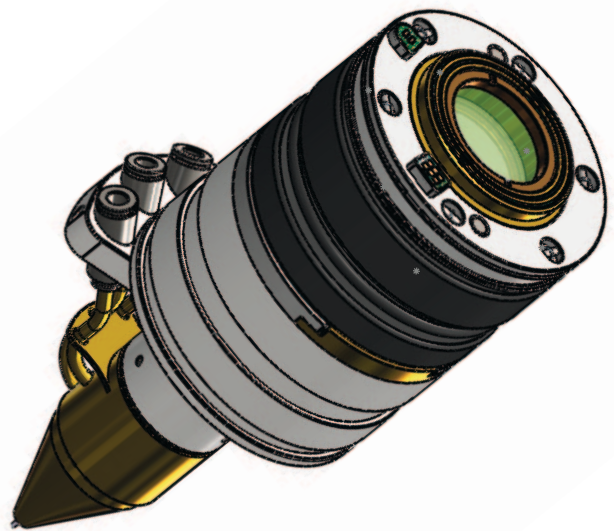

Technical Details

Focal length of focusing lens	200 mm
Powder fineness	Suitable for particle sizes up to 125 µm
Input feed	Central
Powder efficiency	> 80%
Deposition rate	> 5 mm/sec

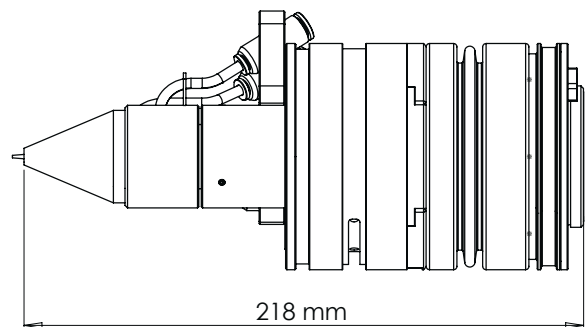
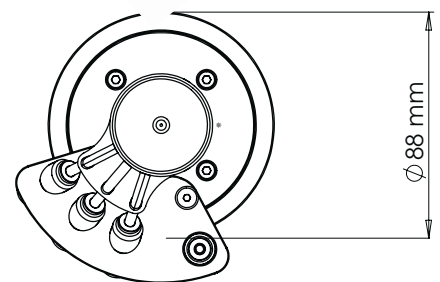

Schematic diagram of powder nozzle

Highlights

- Application of powder independently of the workpiece's direction of movement
- Bayonet mount for quick changing of the cladding head
- Exchangeable protective glass cartridge
- Anti-collision feature

The ORLAS SUITE: An Award-Winning Software Solution for Laser Applications

The ORLAS SUITE from OR Laser is an unprecedented new CAD/CAM environment for planning nearly all facets of laser processing: marking, engraving, cutting, welding, cladding, and powder-based additive manufacturing processes.

The ORLAS SUITE is excellently suited for supporting and planning processing strategies. The software supports the most popular 3D CAD file formats including STEP and IGES. The system also doubles as a tool for classic welding and marking tasks as well

as powder-based laser cladding (also for depositing multiple layers).

This is the first and only comprehensive software for industrial laser applications that is actually able to read and process all proprietary file formats and control all existing laser systems.

For maximum versatility, all of the usual fonts and both bitmap and jpeg files are supported. It is also possible to generate barcodes and QR codes.

One Software Suite – an Infinite Number of Solutions

The ORLAS SUITE combines the functionality of many other software solutions, making it the first one to approach Industry 4.0 standards.

The system is able to combine a photograph of an actual workpiece with a virtual model of it—and do so in real time!

A significant reduction in setup times is achieved by straightforward calibration and teach-in functionality. Virtually any process is facilitated by the latest 3D algorithms as well as creation of and full support

for device drivers for commercially available laser processing systems. The ORLAS SUITE can then be used to automatically or semiautomatically generate G-code defining 2D and 3D processing paths in three or four axes.

Award for “100% Innovation”

This year the ORLAS SUITE was chosen to receive the “Innovation Award IT” from Germany’s “Initiative Mittelstand” in the industry software category. The jury was lavish in its praise:

“We are especially impressed by this excellent product. It ranks among the very best entries received.”

INNOVATIONSPREIS-IT

BEST OF 2015

initiative
mittelstand

BRANCHENSOFTWARE

Strategy for Powder-Based Laser Cladding

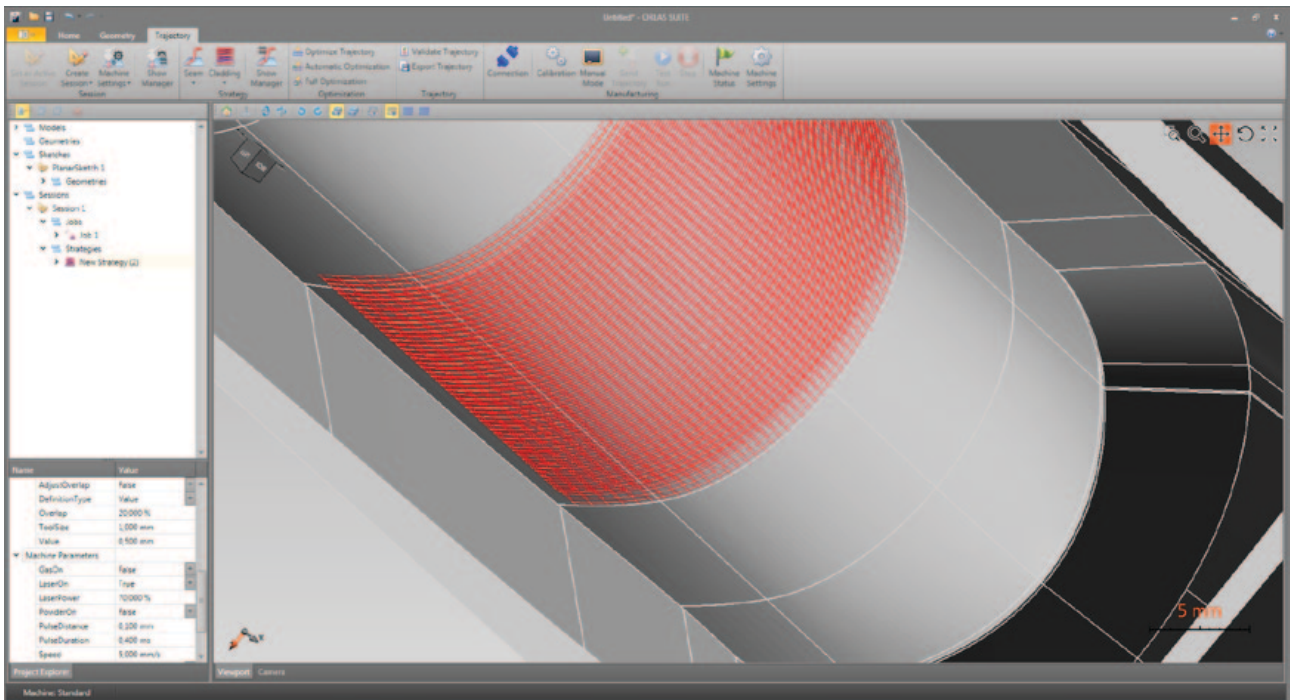

Simulation of the cladding strategy

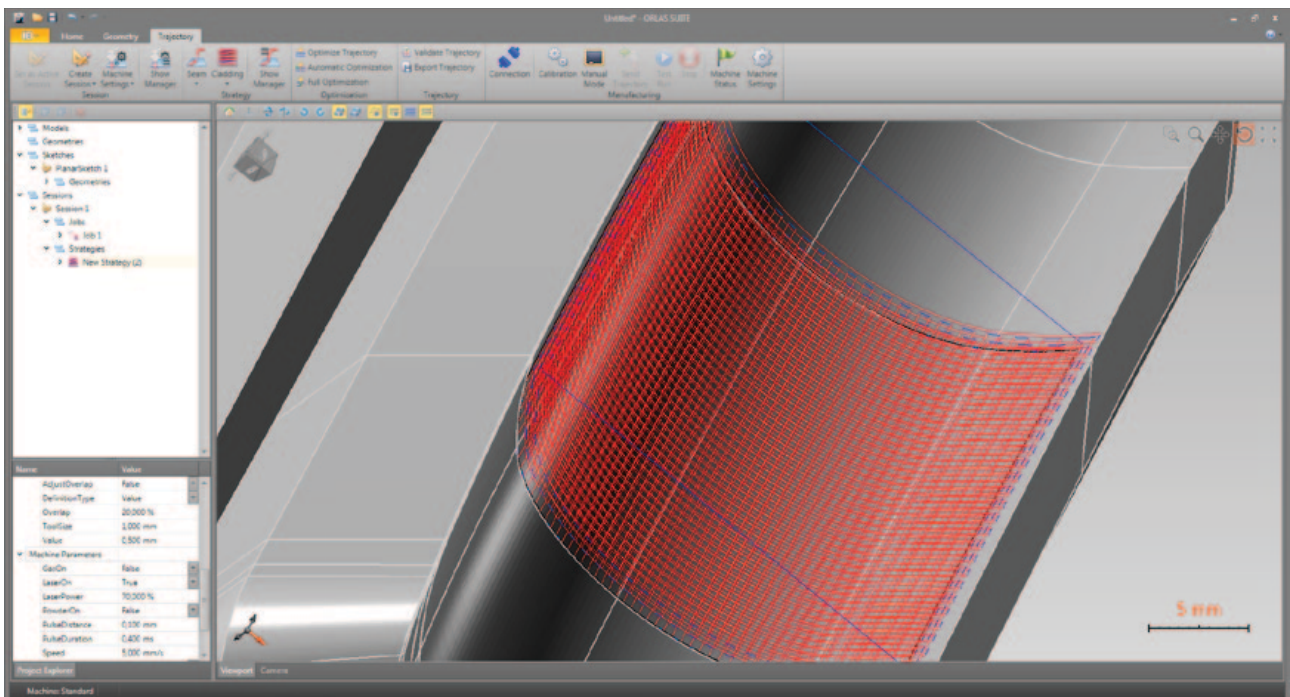

Adaptation of the cladding strategy, here for serpentine lines

DIODELINE Machines: Equipped for the Powder Nozzle from OR Laser



LASERCAB DIODELINE



EVO MOBILE DIODELINE

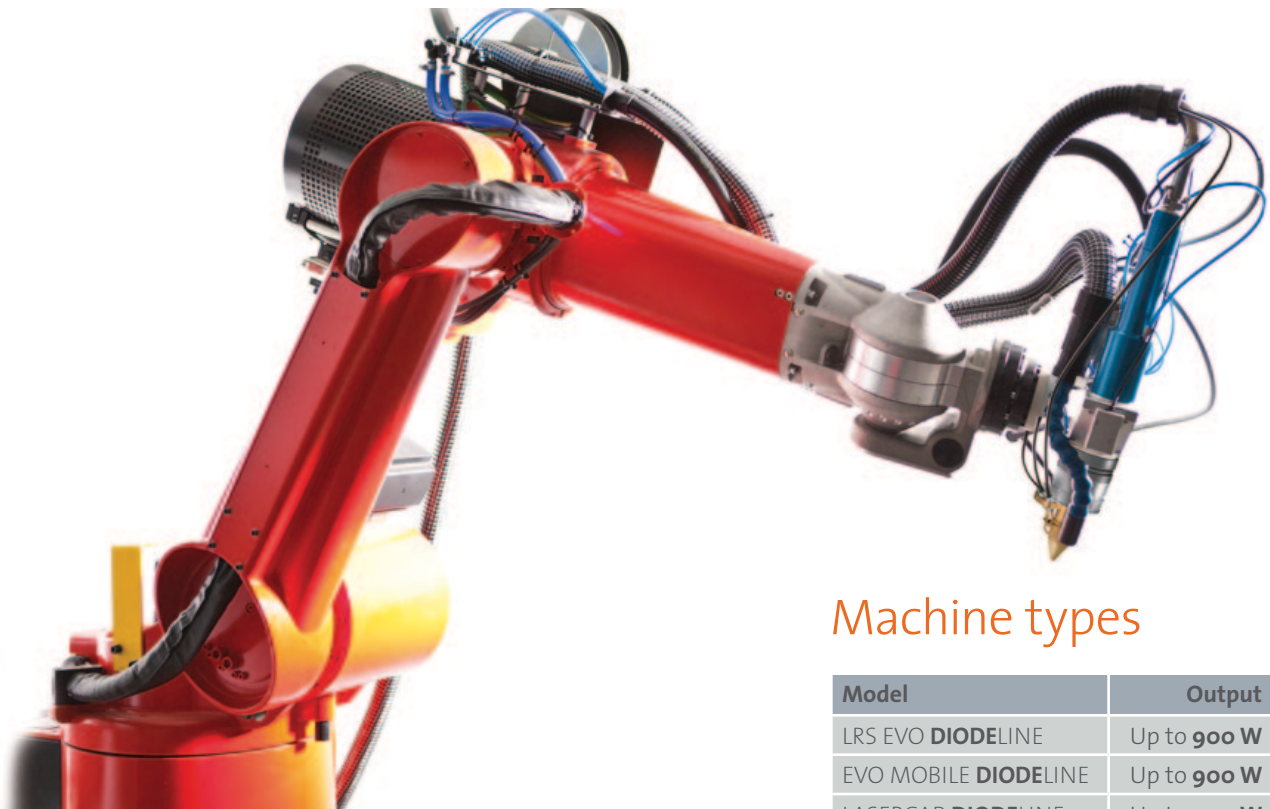

ROBOLASER

Machine types

Model	Output
LRS EVO DIODELINE	Up to 900 W
EVO MOBILE DIODELINE	Up to 900 W
LASERCAB DIODELINE	Up to 900 W
ROBOLASER DIODELINE	Up to 4 kW

Powder Feeder

Best powder-based laser cladding results depend on optimal feeding of the powder, i.e. controlled supply and metering.

With our powder feeder, we have made enormous strides toward attaining this ideal. Hardly any other system offers such a favorable combination of properties.

The feed system is highly versatile and suited for all powder morphologies, including powders with poor or absent flowability. The metering unit is intelligently designed to keep the powder flowing steadily and prevent mixes from reseparating.

A number of parameters can be set—e.g. temperature, gas pressure, and powder flow rate—to optimize the system for virtually any application.

The feeder's see-through design permits easy visual checking. It is optionally available with a scale, and

excellently visualizes and documents the powder feed process.

The system is unaffected by external conditions, it requires only minimal maintenance, and it is easy to load.

Materials

Powder material*	Usability
Steel-based	✓
Nickel-based	✓
Cobalt-based	✓
Carbide-based	✓
Titanium alloys	✓
Aluminum alloys	✓

* The feeder is able to convey any type of powder.



LRS EVO DIODELINE with powder feeder and powder nozzle

wORLD of LASER



HEADQUARTERS

Germany

O.R. Lasertechnologie GmbH
Dieselstrasse 15
64807 Dieburg
Tel.: +49 (0) 6071-209 89 0
Fax: +49 (0) 6071-209 89 99
info@or-laser.de
www.or-laser.de

BRANCHES

USA

O.R. Lasertechnologie Inc.
1420 Howard Street
Elk Grove Village, IL 60007
Tel.: +1 847-593-5711
Fax: +1 847-593-5752
sales@or-laser.com
www.or-laser.com

Israel

M. Shoham Trading LTD
10 Hadeshanim st.
31999 Haifa
Tel.: +972 (0) 4 8726361
info@or-laser.com
www.or-laser.com

Turkey

OR LAZER Kaynak Makinaları
Tic. Ltd. Şti
İkitelli O.S.B İpkas San.
Sit. 9/A Blok No:24
İkitelli K. Çekmece –
Istanbul 34000
Tel.: +90 (0) 212 671 83 30
Fax: +90 (0) 212 671 84 39
info@orlazer.com.tr
www.or-laser.com.tr

India

O.R. LASER TECHNOLOGIE
INDIA P LTD.
Regd Office:
#1 Dhruva Tara · 241
Dr. Rajendra Prasad
Road Tatabad Coimbatore
- 641 012
Tel.: 0422-2493 786/4377 909
info@or-laser.com
www.or-laser.com

Romania

OR Laser Romania
Strada Baciului 2-4
3400 Cluj-Napoca
Tel.: +40 (0)264 436 180
Fax: +40 (0)264 436 181
info@or-laser.com
www.or-laser.com

PARTNERS

Europe

Germany · France · Italy
Switzerland · UK · Spain
Austria · Poland · Portugal
Russia · Serbia · Slovakia
Slovenia · Benelux · Hungary
Czech Republic

Asia

China · Hong Kong · India
Japan · Malaysia · Singapore
South Korea · Thailand

Middle East

United Arab Emirates

Africa

South Africa

Central & South America

Argentina · Brazil
Mexico · Columbia

Ozeania

Australia · New Zealand

